



Standard Practice for Evaluating and Qualifying Oil Field and Refinery Corrosion Inhibitors Using the Rotating Cylinder Electrode¹

This standard is issued under the fixed designation G185; the number immediately following the designation indicates the year of original adoption or, in the case of revision, the year of last revision. A number in parentheses indicates the year of last reapproval. A superscript epsilon (ϵ) indicates an editorial change since the last revision or reapproval.

1. Scope

1.1 This practice covers a generally accepted procedure to use the rotating cylinder electrode (RCE) for evaluating corrosion inhibitors for oil field and refinery applications in defined flow conditions.

1.2 The values stated in SI units are to be regarded as standard. The values given in parentheses are for information only.

1.3 *This standard does not purport to address all of the safety concerns, if any, associated with its use. It is the responsibility of the user of this standard to establish appropriate safety and health practices and determine the applicability of regulatory limitations prior to use.*

2. Referenced Documents

2.1 *ASTM Standards:*²

D1141 Practice for the Preparation of Substitute Ocean Water

D4410 Terminology for Fluvial Sediment

G1 Practice for Preparing, Cleaning, and Evaluating Corrosion Test Specimens

G3 Practice for Conventions Applicable to Electrochemical Measurements in Corrosion Testing

G5 Reference Test Method for Making Potentiostatic and Potentiodynamic Anodic Polarization Measurements

G15 Terminology Relating to Corrosion and Corrosion Testing (Withdrawn 2010)³

G16 Guide for Applying Statistics to Analysis of Corrosion Data

G31 Guide for Laboratory Immersion Corrosion Testing of Metals

¹ This practice is under the jurisdiction of ASTM Committee G01 on Corrosion of Metals and is the direct responsibility of Subcommittee G01.05 on Laboratory Corrosion Tests.

Current edition approved Nov. 1, 2012. Published November 2012. Originally approved in 2006. Last previous edition approved in 2006 as G185 – 06. DOI: 10.1520/G0185-06R12.

² For referenced ASTM standards, visit the ASTM website, www.astm.org, or contact ASTM Customer Service at service@astm.org. For *Annual Book of ASTM Standards* volume information, refer to the standard's Document Summary page on the ASTM website.

³ The last approved version of this historical standard is referenced on www.astm.org.

G46 Guide for Examination and Evaluation of Pitting Corrosion

G59 Test Method for Conducting Potentiodynamic Polarization Resistance Measurements

G96 Guide for Online Monitoring of Corrosion in Plant Equipment (Electrical and Electrochemical Methods)

G102 Practice for Calculation of Corrosion Rates and Related Information from Electrochemical Measurements

G106 Practice for Verification of Algorithm and Equipment for Electrochemical Impedance Measurements

G111 Guide for Corrosion Tests in High Temperature or High Pressure Environment, or Both

G170 Guide for Evaluating and Qualifying Oilfield and Refinery Corrosion Inhibitors in the Laboratory

3. Terminology

3.1 The terminology used throughout shall be in accordance with Terminologies G15 and D4410 and Guide G170.

4. Summary of Practice

4.1 This practice provides a method of evaluating corrosion inhibitor efficiency in a RCE apparatus. The method uses a well-defined rotating specimen set up and mass loss or electrochemical measurements to determine corrosion rates in a laboratory apparatus. Measurements are made at a number of rotating rates to evaluate the inhibitor performance under increasingly severe hydrodynamic conditions.

5. Significance and Use

5.1 Selection of corrosion inhibitor for oil field and refinery applications involves qualification of corrosion inhibitors in the laboratory (see Guide G170). Field conditions should be simulated in the laboratory in a fast and cost-effective manner (1).⁴

5.2 Oil field corrosion inhibitors should provide protection over a range of flow conditions from stagnant to that found during typical production conditions. Not all inhibitors are equally effective over this range of conditions so that is

⁴ The boldface numbers in parentheses refer to the list of references at the end of this standard.

important for a proper evaluation of inhibitors to test the inhibitors using a range of flow conditions.

5.3 The RCE is a compact and relatively inexpensive approach to obtaining varying hydrodynamic conditions in a laboratory apparatus. It allows electrochemical methods of estimating corrosion rates on the specimen and produces a uniform hydrodynamic state across the metal test surface. **(2-21)**

5.4 In this practice, a general procedure is presented to obtain reproducible results using RCE to simulate the effects of different types of coupon materials, inhibitor concentrations, oil, gas and brine compositions, temperature, pressure, and flow. Oil field fluids may often contain sand. This practice does not cover erosive effects that occur when sand is present.

6. Apparatus

6.1 **Fig. 1** shows a schematic diagram of the RCE system. The RCE apparatus consists of a rotating unit driven by a motor that is attached to a sample holder. A system with a range of rotational speeds from 100 to 10 000 rpm with an accuracy of ± 2 rpm is typical. It is essential to be able to rotate the electrode at both low and high speeds and to be able to measure the speed and maintain it at a constant. The accuracy of the rotation rate should be checked. At the side of the sample holder where it is outside the cell, electrical connections to the electrodes are made by a brush contact. It is important for the connection to be as noise free as possible.

6.2 The cylinder geometry is usually defined in terms of the length-to-diameter ratio. Both low and high ratios are used, with ratios varying between 0.3 and 3.0. The rotating cylinder can also be used as a mass loss coupon when the mass loss is sufficiently large to be accurately measured using a conventional balance (with accuracy of 0.1 mg).

6.3 The RCE geometry may have an inner cylinder and an outer cylinder. The geometry is usually defined in terms of the radius of the inner cylinder and the radius of the outer cylinder. When the outer diameter is several times the diameter of the inner electrode the hydrodynamics are essentially controlled by the diameter of the inner rotating cylinder **(2)**. The outer cylinder may act as counter electrode. An RCE with only an inner cylinder may also be used.

6.4 A saturated calomel electrode (SCE) with a controlled rate of leakage or a saturated calomel electrode utilizing a semipermeable membrane or porous plug tip or silver/silver chloride or any other suitable electrode should be used as reference electrode. The potential of the reference electrode should be checked at periodic intervals to ensure the accuracy of the electrode. For experiments at higher-temperature, a higher-pressure, reference electrode arrangement that can withstand higher temperature and pressure should be used **(22)**. This may require special care.

6.5 **Fig. 2** shows a typical rotating electrode unit. A rotating shaft can be modified by drilling a hole in the shaft into which a polytetrafluoroethylene (PTFE) insulator is inserted. Inside the PTFE insulator, a metal rod should be introduced **(Fig. 2)**. One end of the metal rod is threaded so that the cylindrical

electrode can be attached. The other end of the rod is attached directly to the rotating unit, through which the electrical connection is made.

6.6 After attaching the specimen to the shaft, the system should be checked for eccentricity and wobble. This can be accomplished by installing a dial micrometer so as to monitor the location of the top of the rotating cylinder and rotating the shaft slowly through one complete turn. The micrometer should then be moved to monitor the center of the specimen, and the process repeated. Finally the micrometer should be moved to the bottom of the specimen and the process repeated. The assembly should also be rotated at its maximum rotation rate and the specimen wobble checked again using, for example, a laser indicator or vibration monitor.

6.7 Appropriate cylinder specimen (such as, carbon steel) is machined and snugly fitted into the PTFE or any other suitable specimen holder **(Fig. 2)**. The presence of gap between specimen and holder will create crevice corrosion as well as change the flow pattern. If necessary, apply a very small amount of epoxy to fit the specimen into the holder. Tightly attach or screw an end-cap so that only the outer cylindrical area of known length is exposed to the solution. The specimen holder is then attached to the rotating unit. Specimen, holder, and end-cap should all have the same diameter.

6.8 The rotating unit is attached into the experimental vessel, ensuring that there is no leakage through the rotating shaft and the holder and that the rotating shaft is vertically positioned. Even a very slight inclination could drastically change the flow pattern.

6.9 A versatile and convenient apparatus, consisting of a kettle or flask **(Fig. 1)** of suitable size (usually 500 to 5000 mL), inlet and outlet ports for deaeration, thermowell and temperature-regulating device, a heating device (mantle, hot plate, or bath), and a specimen support system, should be used. The volume (of the solution) to surface area (of the specimen) ratio has some effect on the corrosion rate and hence inhibitor efficiencies. A larger volume/surface area (minimum 40 mL/cm²) should be preferred.

6.10 In some cases a wide-mouth jar with a suitable closure can be used, but open-beaker tests should not be used because of evaporation and contamination. Do not conduct the open-beaker test when H₂S (hydrogen sulfide) is used. In more complex tests, provisions might be needed for continuous flow or replenishment of the corrosive liquid, while simultaneously maintaining a controlled atmosphere.

6.11 For experiments above atmospheric pressure, a high-temperature, high-pressure rotating cylinder electrode (HTH-PRCE) system with an electrically isolated electrode system, an electrically isolated motor for rotating the electrode, and a vessel that can withstand high pressure without leakage should be used.

6.12 A design of the vessel that can be used in elevated pressure conditions **(23, 24)** include a standard autoclave **(Fig. 3)** modified by lining on the inside with PTFE. The stirring rod can be modified by drilling a hole into that a PTFE insulator is inserted. Inside the PTFE insulator, a metal rod is introduced.

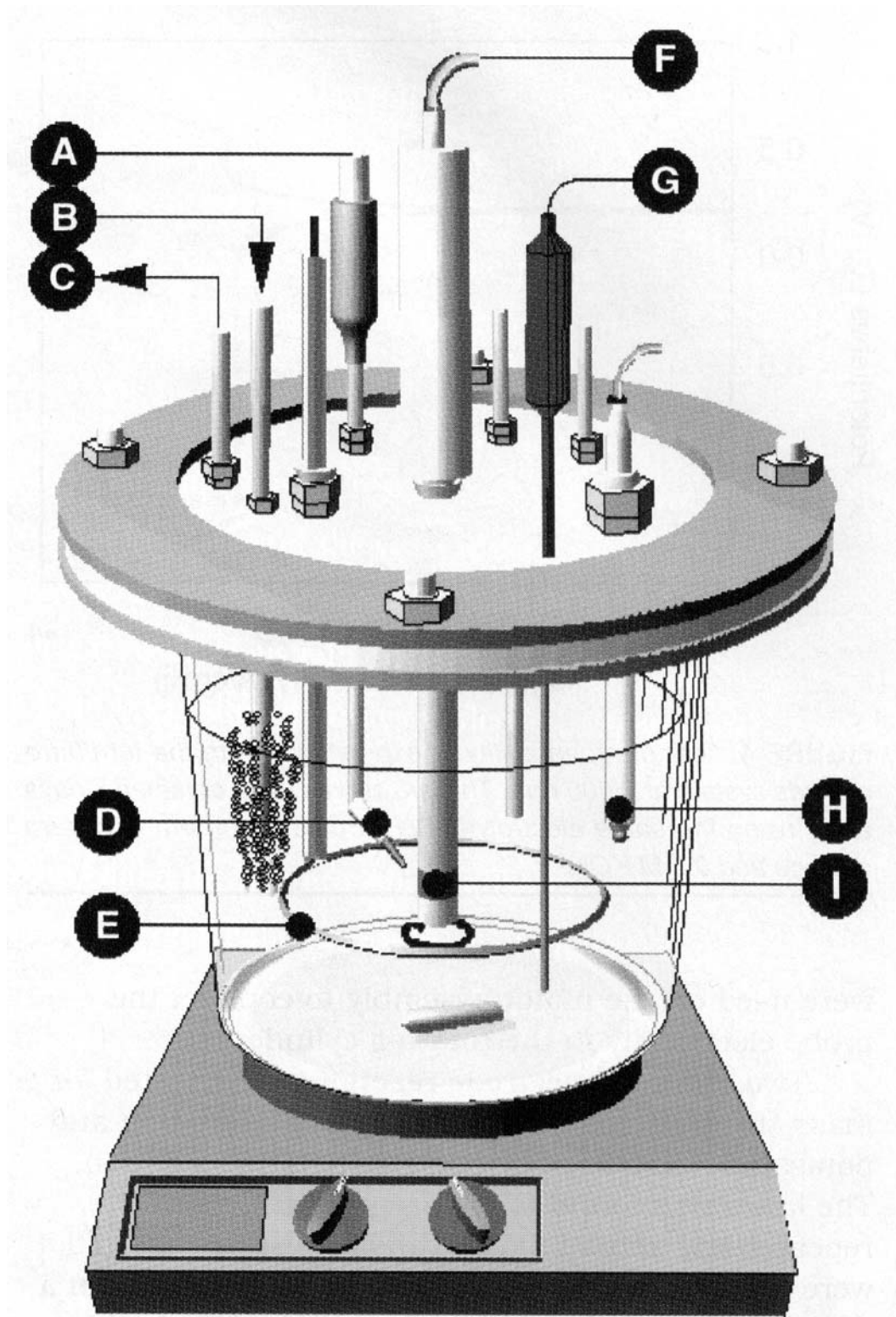

- A. Reference Electrode
- B. Inlet
- C. Outlet
- D. Luggin Capillary
- E. Counter Electrode
- F. Rotating Cylinder
- G. Temperature Probe
- H. pH Electrode
- I. Rotating Cylinder Electrode or Coupon

FIG. 1 Schematic of a RCE System (18)